

Product Information

WH Cylinders CLIMA-BUFF 150L—300L Unvented Domestic Hot Water Cylinders



**High quality British
manufactured stainless steel
domestic hot water solutions
designed for any application.**



Tudor House
Tudor Industrial Estate
Ashton Street
Dukinfield
Cheshire
SK16 4RN

Tel: 0161 343 8610
Fax: 0161 826 1661
Email: sales@whcylinders.co.uk

WH Cylinders manufacture a full range of Unvented combined heat pump and buffer vessel in one integrated case.

All of our cylinders are manufactured from high quality stainless steel under an ISO9001 certified quality management system in our purpose made manufacturing facility in Manchester.

Key Features

- Combined buffer vessel & cylinder
- High quality stainless steel
- 25 Year manufacturing warranty subject to annual maintenance.
- Highly insulated Part L compliant
- Full system unvented kits
- ISO9001 certified quality management
- Pre-plumbed models available

CLIMA-BUFF RANGE

WH Cylinders CLIMA-BUFF 150L—300L Unvented Domestic Hot Water Cylinders



WORLD HEAT
CYLINDERS

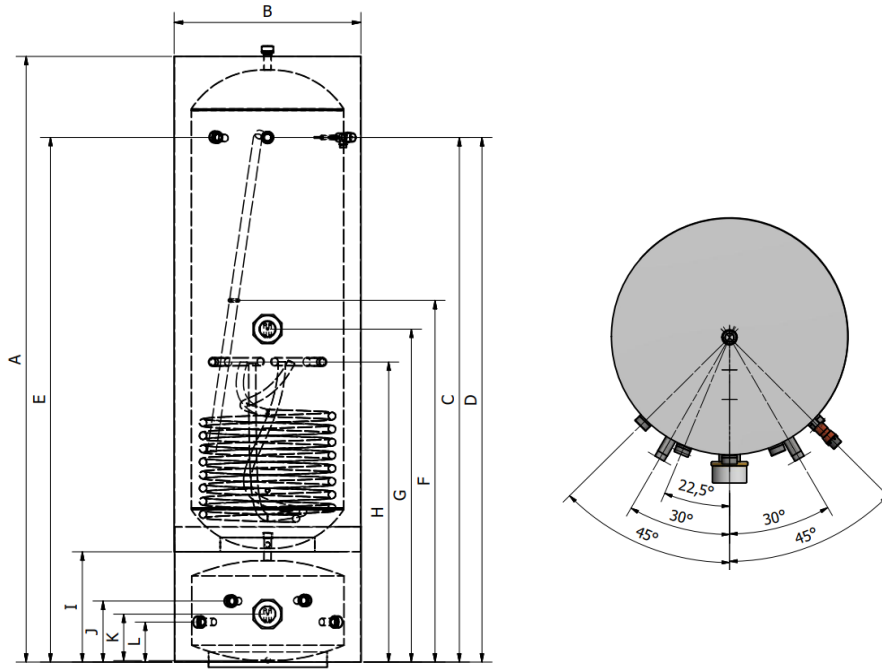

Capacity	A (Overall Height)	B (Overall Diam)	C (Cold Feed)	D (T&P Valve)	E (Sec. Return)	F (Sensor Pocket)	G (Electric Heater)	H (Coils F & R)	I (Buffer Height)	J (Buffer F&R)	K (Buffer Heater)	L (Buffer F & R)
150L	1505	550	1295	1295	1295	1095	1015	915	350	230	147	110
180L	1630	550	1403	1403	1403	1095	1015	915	350	230	147	110
210L	1820	550	1599	1599	1599	1095	1015	915	350	230	147	110
250L	2020	550	1790	1790	1790	1095	1015	915	350	230	147	110
300L	2020	600	1785	1785	1785	1325	1225	1155	440	250	225	200
Nominal capacity (Litres)					150	180	210	250	300			
Overall packaged dimensions H x W x D (mm)					1605x600x900	1730x600x900	1920x600x900	2120x600x900	2120x600x900			
Approximate Weight (KG)		Empty	65.5	69.5	75	81	88					
		Full	215.5	249.5	285	331	388					
		Packaged	77	81	86	92	99					
Control & relief valve pressure settings		Pressure Reducing & Relief Valve	3 Bar / 6 Bar	3 Bar / 6 Bar	3 Bar / 6 Bar	3 Bar / 6 Bar	3 Bar / 6 Bar					
		Exp Vessel	12L	12L	18L	18L	24L					
		T & P Valve	7 Bar	7 Bar	7 Bar	7 Bar	7 Bar					
Buffer Vessel Capacity		50 Litres / 100 Litres (Dimensions will differ on 100L buffer)										
Immersion Heater		1 x 3KW Single Phase - 230V - 50hz										
Cylinder Material		Duplex Stainless Steel										
Buffer Vessel Material		Mild Steel										
Insulation Type		Polyurethane (PU) Insulation with CO2 Blowing Agent										
Insulation thickness (mm)		50	50	50	50	50						
Standing heat loss		62	65	76	86	96						
GWP of Insulation		Less than 5	Less than 5	Less than 5	Less than 5	Less than 5						
ODP of Insulation		0	0	0	0	0						
ERP Rating		C	C	C	C	C						

