

Product Information Sheet

WH Cylinders

EcoTherm Direct Self Fill Thermal Store **Slim**

150 Litre to 180 Litre Stainless Steel



WORLD HEAT
CYLINDERS



**High quality British
manufactured Stainless Steel
Thermal Stores designed for any
application.**

**WH Cylinders manufacture a full range of
Thermal store cylinders for any application.**

All of our cylinders are manufactured from high quality Stainless Steel under an ISO9001 certified quality management system in our purpose built manufacturing facility in Manchester.

Key Features

- **High quality Stainless Steel**
- **25 Year manufacturing warranty**
- **Highly insulated Part L compliant**
- **Full Pre Plumbed system kits provided**
- **ISO9001 certified quality management**



Tudor House
Tudor Industrial Estate
Ashton Street
Dukinfield
Cheshire
SK16 4RN

Tel: 0161 343 8610
Fax: 0161 343 5585
Email: sales@whcylinders.co.uk

Product Information Sheet

WH Cylinders

EcoTherm Direct Self Fill Thermal Store Slim

150 Litre to 180 Litre Stainless Steel



WORLD HEAT
CYLINDERS

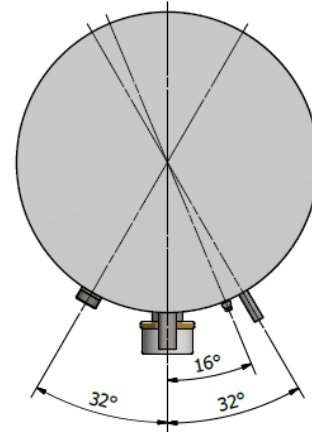
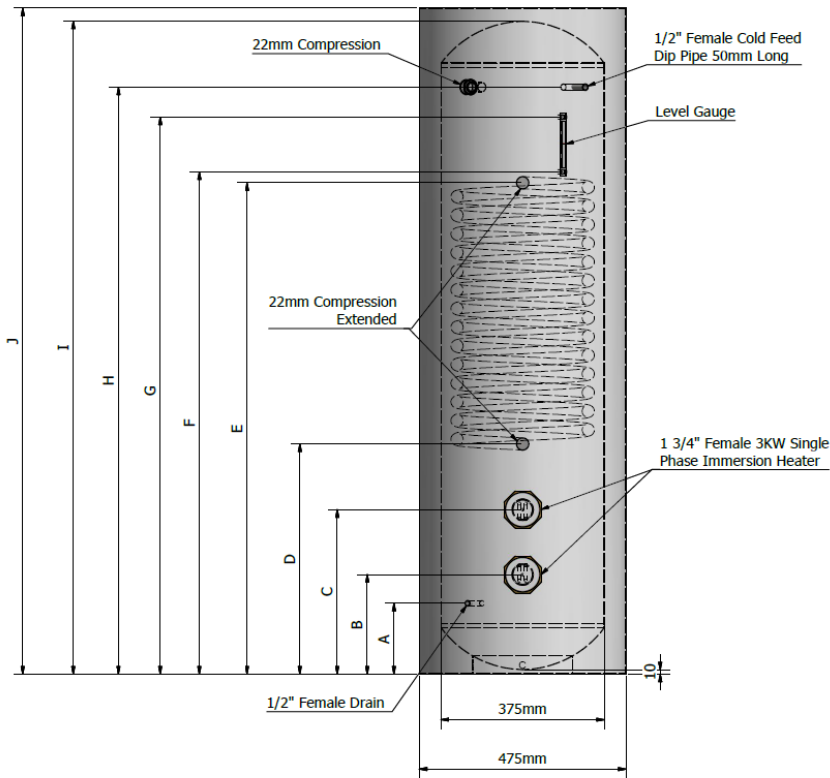

| Dimension | A | B | C | D | E | F | G | H | I | J |
|--------------------------|--------------|------------------|------------------|------------------|----------------|-------------|-------------|----------------------------------|--------------------|--------------------------|
| Capacity (Litres) | 1/2" F Drain | 1 3/4" Immersion | 1 3/4" Immersion | 22mm Coil Return | 22mm Coil Flow | Level Gauge | Level Gauge | 22mm Secondary Return/ Cold feed | Cylinder Dimension | Cased Cylinder Dimension |
| 150 | 160mm | 260mm | 480mm | 639mm | 1039mm | 1059mm | 1185mm | 1274mm | 1480mm | 1530mm |
| 180 | 160mm | 260mm | 680mm | 953mm | 1353mm | 1373mm | 1499mm | 1588mm | 1790mm | 1840mm |

| Model | | 150FISCHSLIM | 180FISCHSLIM |
|--|----------|----------------|----------------|
| Nominal capacity | | 150 Litres | 180 Litres |
| Overall packaged dimensions HxWxD (mm) | | 1630mm x 520mm | 1940mm x 520mm |
| Cylinder Size | | 1530mm x 470mm | 1840mm x 470mm |
| Approximate Weight | Empty | 30KG | 35KG |
| | Full | 180KG | 215KG |
| | Packaged | 35KG | 40KG |

Tudor House
Tudor Industrial Estate
Ashton Street
Dukinfield
Cheshire
SK16 4RN

Tel: 0161 343 8610
Fax: 0161 343 5585
Email: sales@whcylinders.co.uk

