

## Product Information

### WH Cylinders

### Climacyl— Unvented Heat pump & Solar Cylinders

120L—300L



**WORLD HEAT**  
CYLINDERS



**High quality British  
manufactured stainless steel  
domestic hot water solutions  
designed for any application.**

**WH Cylinders manufacture a full range of  
unvented mains pressure domestic hot water  
cylinders for any application.**

All of our cylinders are manufactured from high quality stainless steel under an ISO9001 certified quality management system in our purpose made manufacturing facility in Manchester.

#### Key Features

- **High quality stainless steel**
- **25 Year manufacturing warranty**
- **Only 475mm diameter**
- **Highly insulated Part L compliant**
- **Full system unvented kits**
- **WRAS approved product**
- **ISO9001 certified quality management**
- **Pre-plumbed models available**



Tudor House  
Tudor Industrial Estate  
Ashton Street  
Dukinfield  
Cheshire  
SK16 4RN

**Tel:** 0161 343 8610  
**Fax:** 0161 343 5585  
**Email:** sales@whcylinders.co.uk

# Climacyl Dimensional Drawing

## WH Cylinders

### Climacyl— Unvented Heat pump & Solar Cylinders

#### 120L—300L



**WORLD HEAT**  
CYLINDERS

50mm Polyurethane Insulation  
White Finished Casing  
Bespoke cylinders available at request

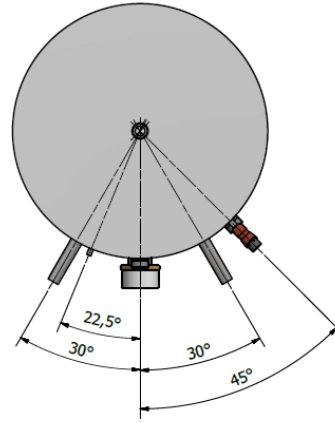
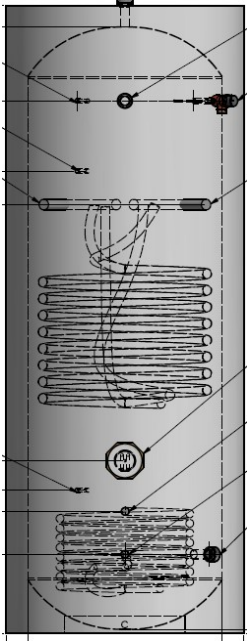

\*All dimensions in mm  
\*\* Connection dimensions may differ from this table

Dimension	A	B	C	D	E	F	G	H	I	J	K	L
Capacity (Litres)	Height & 22mm Comp Hot Draw off	Diameter	22mm Comp C/Feed & 22mm Stub Return	28mm Stub Coil Flow	Stat Pocket	1 3/4" Female Immersion Heater	22mm Stud Pipe Flow	22mm Stud Pipe Return	Stat Pocket	22mm Comp 2nd Return	1/2" Temp and Pressure Relief	Stat Pocket
150	1150mm	550mm	190mm	270mm	320mm	340mm	780mm	780mm	800mm	840mm	880mm	880mm
180	1270mm	550mm	190mm	270mm	320mm	420mm	906mm	906mm	950mm	1000mm	1056mm	1056mm
210	1500mm	550mm	190mm	270mm	320mm	420mm	906mm	906mm	1044mm	1119mm	1194mm	1194mm
250	1764mm	550mm	190mm	270mm	320mm	625mm	1275mm	1275mm	1325mm	1475mm	1500mm	1500mm
300	2050mm	550mm	190mm	270mm	320mm	625mm	1275mm	1275mm	1325mm	1475mm	1807mm	1807mm

Nominal capacity (Litres)		120	150	180	210	250	300
Overall packaged dimensions H x W x D (mm)		1000 x 600 x 600	1250 x 600 x 600	1320 x 600 x 600	1550 x 600 x 600	1810 x 600 x 600	2150 x 600 x 600
Approximate Weight (KG)	Empty	35	40	45	50	55	60
	Full	155	190	225	260	305	360
	Packaged	45	50	55	60	65	70
Control & relief valve pressure settings	Pressure Reducing & Relief Valve	3 Bar / 6 Bar	3 Bar / 6 Bar	3 Bar / 6 Bar	3 Bar / 6 Bar	3 Bar / 6 Bar	3 Bar / 6 Bar
	Exp Vessel	12L	12L	12L	18L	18L	24L
	T & P Valve	7 Bar	7 Bar	7 Bar	7 Bar	7 Bar	7 Bar
Immersion Heater	3KW Single Phase - 230V - 50hz						
Cylinder Material	Duplex Stainless Steel						
Insulation Type	Polyurethane (PU) Insulation with CO2 Blowing Agent						
Insulation thickness (mm)	50						
Standing heat loss (Kwh/Annum)	57.9    61.5    65.3    76.3    86.4    95.6						
GWP of Insulation	Less than 5						
ODP of Insulation	0						
ERP Rating	C						

\* Solar twin coil units available on request

\*\* Bespoke cylinders available on request

