

# Product Information Sheet—ECOTHERM

WH Cylinders

EcoTherm Indirect Self Fill Thermal Store **Standard**

150 Litre to 210 Litre



**WORLD HEAT**  
CYLINDERS



**High quality British  
manufactured Stainless Steel  
Thermal Stores designed for any  
application.**

**WH Cylinders manufacture a full range of  
Thermal store cylinders for any application.**

All of our cylinders are manufactured from high quality Stainless Steel under an ISO9001 certified quality management system in our purpose built manufacturing facility in Manchester.

### Key Features

- **High quality duplex stainless steel**
- **10 Year manufacturing warranty**
- **Highly insulated Part L compliant**
- **Full Pre Plumbed system kits provided**
- **Primary indirect boiler coil**
- **1 x 3KW Immersion Heaters**



Tudor House  
Tudor Industrial Estate  
Ashton Street  
Dukinfield  
Cheshire  
SK16 4RN

**Tel:** 0161 343 8610  
**Fax:** 0161 343 5585  
**Email:** sales@whcylinders.co.uk

# Product Information Sheet—FISCHER

## WH Cylinders

### EcoTherm Indirect Self Fill Thermal Store Standard



**WORLD HEAT**  
CYLINDERS

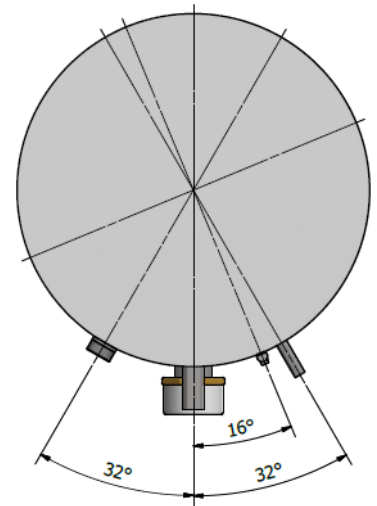
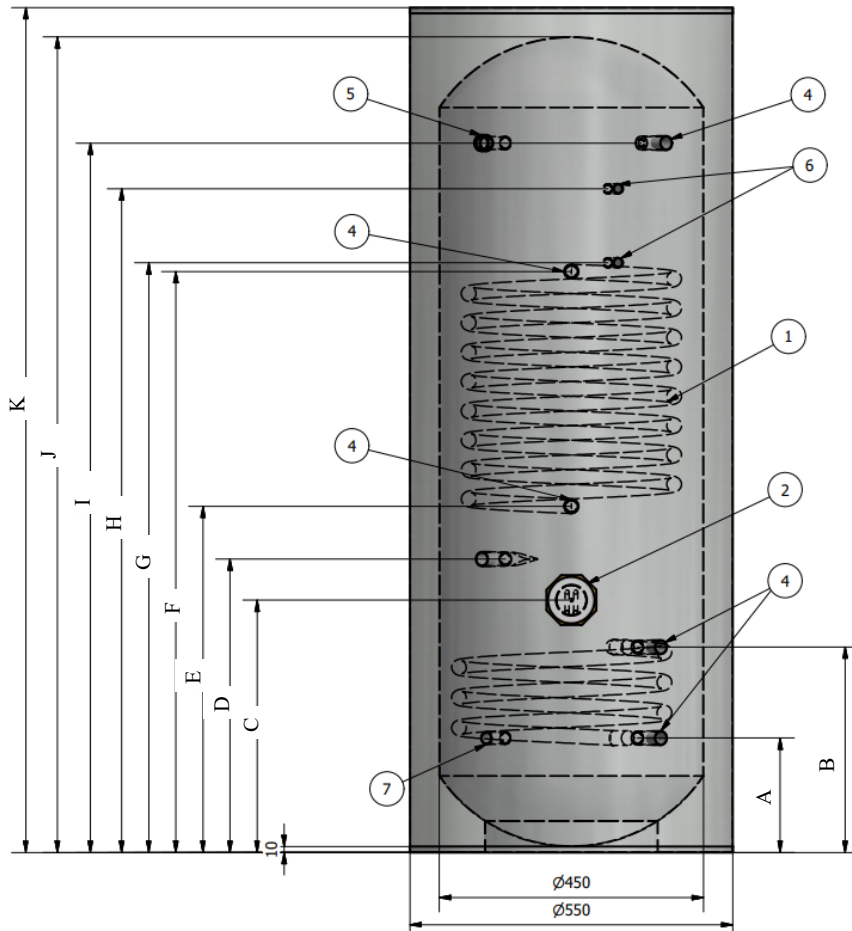

\* Dimensions may differ on final product

Dimension	A	B	C	D	E	F	G	H	I	J	K
Capacity (Litres)	22mm stub primary coil return	22mm stub primary coil flow	1 3/4" Immersion	Stat pocket	Cold feed 22mm DHW Coil Flow	DHW hot water outlet	Level Gauge	Level Gauge	22mm Overflow	Cylinder Dimension	Overall Height
150	100mm	155mm	550mm	655mm	1055mm	1075mm	1075mm	1201mm	1280mm	1380mm	1440mm
180	100mm	155mm	650mm	804mm	1204mm	1224mm	1224mm	1350mm	1439mm	1539mm	1589mm
210	100mm	155mm	700mm	955mm	1355mm	1375mm	1375mm	1501mm	1590mm	1690mm	1740mm

Model		150ECOTHERM-SF-ISS	180ECOTHERM-SF-ISS	210ECOTHERM-SF-ISS
Nominal capacity		150 Litres	180 Litres	210 Litres
Overall packaged dimensions H x W x D (mm)		1540mm x 600mm	1689mm x 600mm	1840mm x 600mm
Cylinder Size		1440mm x 550mm	1589mm x 550mm	1740mm x 550mm
Approximate Weight	Empty	35KG	40KG	45KG
	Full	185KG	220KG	255KG
	Packaged	40KG	45KG	50KG
Cylinder Material		Stainless Steel Duplex 2101		
Insulation Type		Polyurethane (PU) Insulation		
Standing Heat Loss (Watts)		61.5	65.3	76.3
Primary boiler coil rating (80/60 deg C) KW		15	15	15

Tudor House  
Tudor Industrial Estate  
Ashton Street  
Dukinfield  
Cheshire  
SK16 4RN

Tel: 0161 343 8610  
Fax: 0161 343 5585  
Email: sales@whcylinders.co.uk

